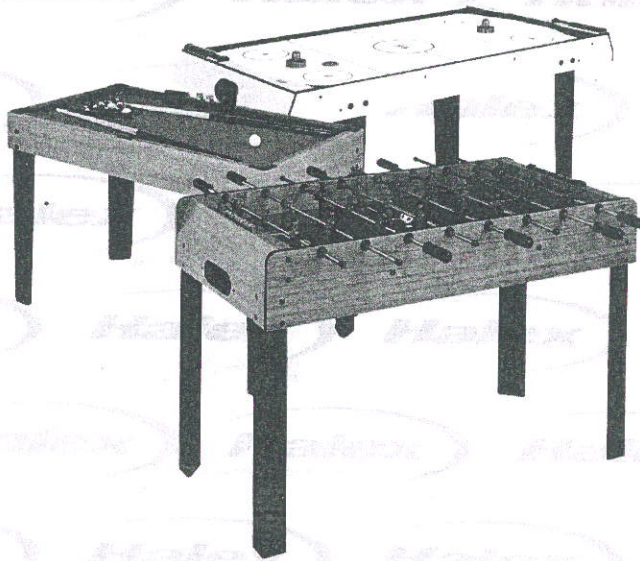

TABLE  
**Games**

*Assembly instructions*



50144

**Halex**  
TM

## **LIMITED 90 DAY WARRANTY**

This Halex product is warranted to be free from defects in workmanship or materials at the time of purchase for a period of 90 (ninety) days. Certain restrictions apply (see below).

Should any evidence of defects appear within the limited warranty period after the date of purchase, Regent Sports will either send replacement parts or advise of another course of action. A list of replaceable parts can be found on the parts order form page of this manual. Parts not listed on this order form are not replaceable. **Table tops, playing surfaces, and main frames are not replaceable.** This warranty covers normal consumer use and does not cover failures, which result from alterations, accidents, misuse, abuse, or neglect.

For prompt warranty service and special offers, please register your Halex product at our customer service center by visiting our website at: [www.regent-halex.com](http://www.regent-halex.com). Enter the following unique registration number followed by the item number of your table found on the cover of this manual: 1ZAK7 \_\_\_\_\_. You must register your product within 30 days of purchase to be eligible for warranty service. Please make sure to visit our website to order additional parts not covered under the warranty, as well as on-line instruction manuals and new product information. You may also order parts by calling our automated voice recognition system at: 877-516-9707 (Toll Free).

**A purchase receipt or other proof of date of purchase will be required before warranty service is performed.** Requests for warranty service can be provided by e-mailing the customer service department at [cstables@regent-halex.com](mailto:cstables@regent-halex.com) or by calling customer service at:

**877-516-9707 (Toll Free)**

**10:00 AM to 6:00 PM, EST. (Dec. through Jan.)**

**10:00 AM to 5:00 PM, EST. (Feb. through Nov.)**

Or send request in writing to:

**Regent Sports Corporation**  
45 Ranick Road  
Hauppauge, NY 11788  
Attn: Halex Customer Service

This warranty gives you specific legal rights and you may have other rights that vary from state to state.

## Foosball Table Game Rules

### To Start a Match:

- A coin flip shall precede the start of the match. The team that wins the flip has the choice of table side or first serve.

### The Serve:

- A serve through the serving hole is used to put the ball into play at the start of the match, after a point is scored, or after a ball leaves the table.

### Subsequent Serves:

- Following the first serve of the match, subsequent serves shall be made by the team last scored upon.

### Ball in Play:

- Once a ball is put in play by the server, it shall remain in play until the ball is hit off the table, a dead ball is declared, time out is called, or a point is scored.

### Ball Off the Table:

- The ball should be put back into play with a serve by the team which originally served that ball.

### Dead Ball:

- A ball shall be declared dead when it has completely stopped its motion and is not within reach of any player figure.
- If the ball is declared dead between the goalie and the 2-man rods, it shall be put back into play by placing the ball in the corner nearest the spot of the dead ball.
- If the ball is declared dead anywhere else on the table, it shall be put back into play with a serve by the team that originally served that ball.

### Point Scored:

- A ball entering the goal shall count as a point, as long as it was legally scored. A ball which enters the goal but returns to the playing surface and/or leaves the table still counts as a goal.

### Change of Positions:

- In any doubles event, each player may play only the two rods normally designated for his position. Once the ball is put into play, the players must play the same position until a point is scored.

### Spinning the Rods:

- Spinning the rods is illegal. Spinning is defined as the rotation of any soccer figure more than 360 degrees before or after striking the ball.
- If the ball goes in the goal, then it will not be counted as a point and will be put back into play by the goalie as if the ball had been declared a dead ball between the goal and the nearest two-man rod.











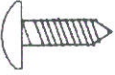
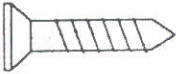
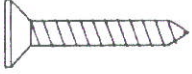
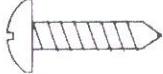

### Jarring:

- Any jarring, sliding, or lifting of the table shall be illegal.

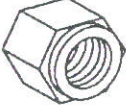
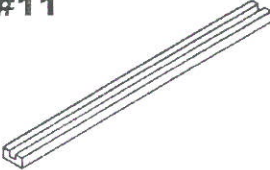
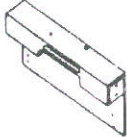

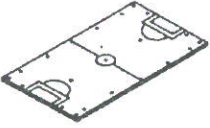

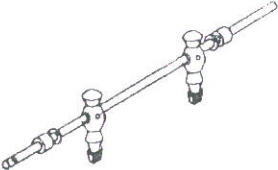
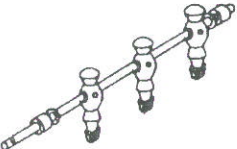
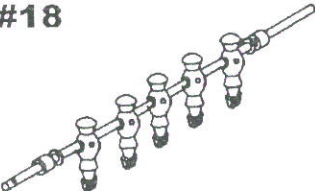
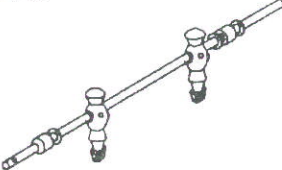
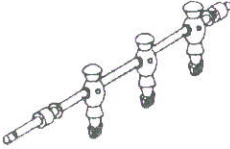
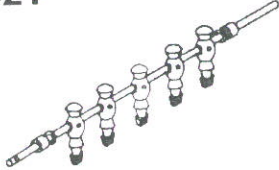
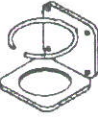



### Reaching Into The Playing Area:

- It is illegal for a player to reach into the playing area while the ball is in play.

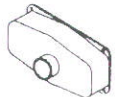
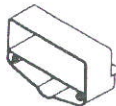
# 50144 Parts List

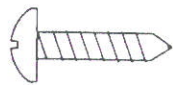
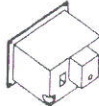
<p><b>#1</b></p>  <p>bolt 16pieces</p>	<p><b>#2</b></p>  <p>washer 16pieces</p>	<p><b>#3</b></p>  <p>bolt 8pieces</p>	<p><b>#4</b></p>  <p>washer 12pieces</p>
<p><b>#5</b></p>  <p>round head screw 12pieces</p>	<p><b>#6</b></p>  <p>flat head screw 14pieces</p>	<p><b>#7</b></p>  <p>flat head screw 4pieces</p>	<p><b>#8</b></p>  <p>round head screw 18pieces</p>
<p><b>#9</b></p>  <p>support rod 2pieces</p>	<p><b>#10</b></p>  <p>nut 4pieces</p>	<p><b>#11</b></p>  <p>playfield support brace2 pieces</p>	<p><b>#12</b></p>  <p>end panel 2 pieces</p>
<p><b>#13</b></p>  <p>side panel 2pieces</p>	<p><b>#14</b></p>  <p>playing field 1piece</p>	<p><b>#15</b></p>  <p>leg 4pieces</p>	<p><b>#16</b></p>  <p>2 Ivory home players rod 1 piece</p>
<p><b>#17</b></p>  <p>3 Ivory home players rod 2 pieces</p>	<p><b>#18</b></p>  <p>5 Ivory home players rod 1 piece</p>	<p><b>#19</b></p>  <p>2 red away players rod 1 piece</p>	<p><b>#20</b></p>  <p>3 red away players rod 2 pieces</p>
<p><b>#21</b></p>  <p>5 red away players rod 1 piece</p>	<p><b>#22</b></p>  <p>cup holder 2 pieces</p>	<p><b>#23</b></p>  <p>slide scorer 2 pieces</p>	<p><b>#24</b></p>  <p>ball entry cup 2 pieces</p>

# 50144 Parts List

<p><b>#25</b></p>  <p>leg leveler 4 pieces</p>	<p><b>#26</b></p>  <p>rod handle 8 pieces</p>	<p><b>#27</b></p>  <p>rod end cap 8 pieces</p>	<p><b>#28</b></p>  <p>ball catcher 2pieces</p>
<p><b>#29</b></p>  <p>goal 2pieces</p>	<p><b>#30</b></p>  <p>ball runner 2pieces</p>	<p><b>#31</b></p>  <p>round head screw 4 pieces</p>	<p><b>#32</b></p>  <p>control switch 1 piece</p>
<p><b>#33</b></p>  <p>soccer ball 2pieces</p>	<p><b>#34</b></p>  <p>tool 1 piece</p>	<p><b>#35</b></p>  <p>tool 2 pieces</p>	

Step 1 – slide the player rods (#16- #21) through the holes in a side panel #13. Follow diagram to make sure that the rods go into their appropriate holes in the side panel. Be sure the small hole at the end of the home player rods Player #16, #17, and #18 is through the side panel. The small hole at the away rod #19, #20 and #21 should be furthest the side panel.

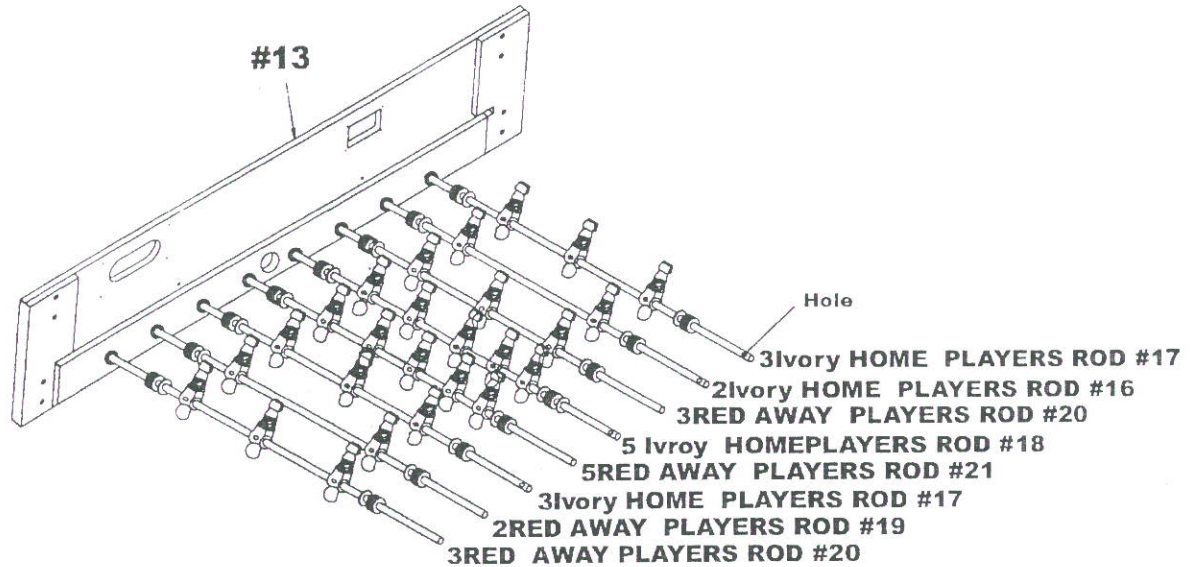

Step 2 – Slide the other rod ends through the other side panel #13. Next, slide the playing field #14 face down into the grooves in the side panels shown in diagram.

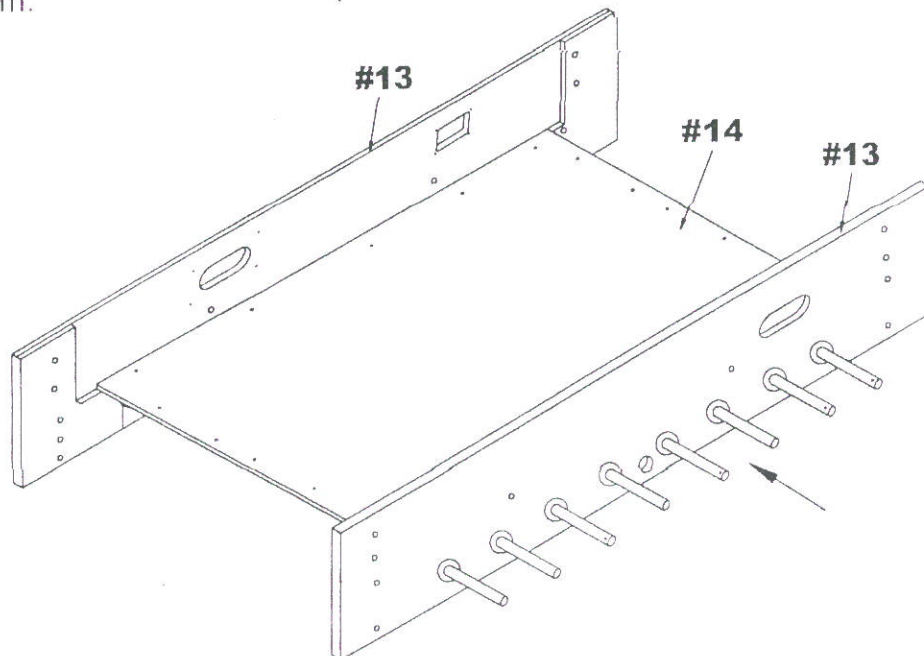

Step 3- Attach the end panels #12 to the side panels with bolts #3 and washers #4. Secure the playing field by screwing in the round head screws #8 into the pre-drilled holes shown in diagram.

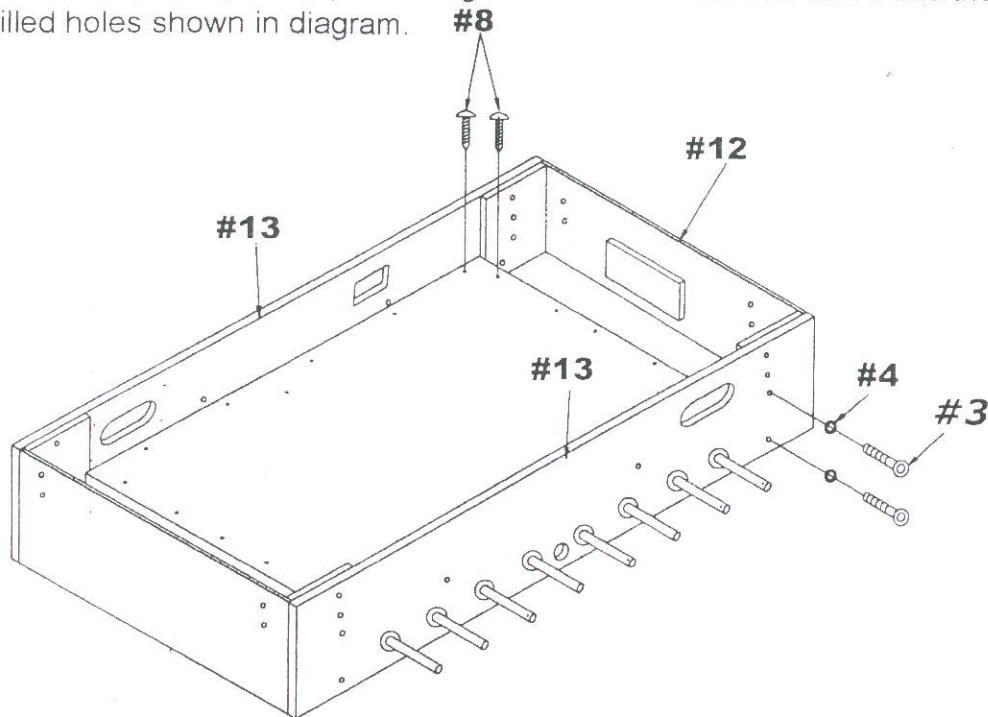

Step 4- Place the playfield Support Brace #11 on the playing field so the groove is facing up. Slide the support rods #9 through the appropriate holes in the side panel and through the grooves in the playfield Support Brace. Tighten these rods using washer #4 and nut #10. Next attach the ball catchers #28 to the side panels by placing them in the holes and securing with the round head screws #5. Attach the goals #29 to the end panels by placing them in the holes and securing with the round head screws #5. Connect the ball catchers #28 and goals #29 with the ball runner #30. Place the control switch #32 into the square hole in the side panel and secure with the round head screws #31 shown in diagram.

