

# *Manchester*

## Electronic Dartboard

And Cabinet

---

**Owner's Manual**  
**And Game Instructions**



***Computer Opponent***

### **LIMITED 1 YEAR WARRANTY**

This Halex product is warranted to be free from defects in workmanship or materials at the time of purchase for a period of 1 year.

Should any evidence of defects in materials or workmanship appear within the limited warranty period after the date of purchase, Regent Sports will either repair or replace the dartboard at its option. This warranty covers normal consumer use and does not cover failures, which result from alterations, accidents, misuse, abuse, or neglect.

DO NOT RETURN the dartboard to the store where purchased, as they are not equipped to handle repairs. All warranty or repair requests require a Return Authorization Number from Regent Sports.

A purchase receipt or other proof of date of purchase will be required before warranty service is performed. Requests for warranty service can be provided by calling the Customer Service Department at 877-516-9707 (Toll-Free), between 10:30 AM and 7:00 PM, EST. Or send request in writing to:

**Regent Sports Corporation**  
45 Ranick Road  
Hauppauge, NY 11788  
Attn: Halex Customer Service

This warranty gives you specific legal rights and you may have other rights, which vary, from state to state.

## **Unpacking the Game**

Unpack your new dartboard carefully, making sure all parts are included. The following components are included in this set:

- 1 Electronic Dartboard
- Cabinet
- A/C Adapter
- 24 Darts (unassembled)
- Soft tip replacement pack
- 2 Cabinet mounting screws with drywall anchors
- 4 dartboard mounting screws
- Owner's Manual

**If you are missing a part or have any questions, please call our Customer Service Department between 10:30 AM and 7:00 PM, EST. at 877-516-9707 (Toll-Free).**

***A protective film has been applied to the display and button areas to prevent scratching. See page 5 for removal instructions***

## Setup / Mounting Instructions

Choose a location to hang the dartboard where there is about 10 feet of open space in front of the board. The "toe-line" should be 7' 9 1/4" from the face of the dartboard. Since this dartboard can be powered with the included AC adapter, you may want to mount it close to an electric outlet for convenience.

Locate a wall stud and place a mark 79 3/4" from the floor. Place another mark at the same height 16" from the first mark. Due to the weight of the dartboard and cabinet, it is recommended you mount onto the wall studs. If this is not possible, we have included 2 drywall anchors. **Bullseye height should be 5' 8" from the floor.**

Screw 2 cabinet mounting screws (long) in the center of the stud using the marks you made as guides. Be sure the screws are level with one another (use a level for accuracy) to ensure dartboard will be level.

Mount the dartboard to the cabinet before mounting to wall. Lay cabinet on floor with doors open. Note the 4 screw receivers embedded in the backboard of the cabinet. Place the dartboard into the cabinet and line up holes with screw receivers. The holes on the dartboard are located in the catch ring area outside the scoring segment area. Using a small Philips-head screwdriver, screw the dartboard mounting screws into the receivers. The dartboard is now attached securely to the cabinet.

To mount the cabinet to the wall, simply line up the screws on the wall with the hang brackets located on the back of the cabinet (top edge). It may be necessary to adjust the screws until the board fits snugly against the wall.

Plug the A/C adapter into the wall outlet and into the jack at the bottom right of the dartboard through the hole in the right side of the cabinet.

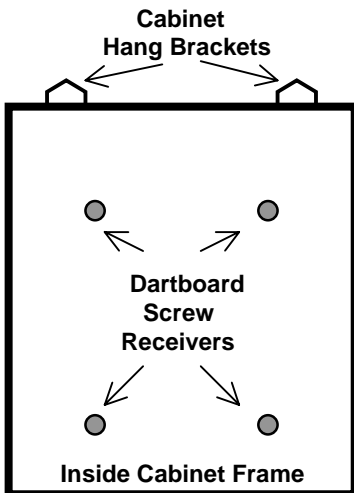

***Cabinet Diagram***

***Wall Diagram***

## **Dartboard Functions (see pages 22 and 23 for diagram)**

**POWER switch** - Located on side of the dartboard, near the AC adapter jack, press this switch to turn game on ("I") or off ("O"). This can be accessed through side of cabinet.

**GAME button** - Press to page through the on-screen game menu.

**SELECT button** - Press to select various difficulty settings for games. Many games contain several difficulty options that can be accessed by pressing this button.

**PLAYER button** - This button is used at the start of each game to select the number of players you want to play the game. In addition, this button allows players to see other player scores of not on active display. This dartboard keeps track of up to 8 player scoring

**DOUBLE/MISS button** - This button is used to activate the Double In/Double Out option for the "01" games. This function is only active when selecting 301, 401, etc. games. This button is also used to register a "missed" dart. Player can press when dart lands outside target area so computer registers a thrown dart.

**SOUND switch** - Set to volume level of choice; MAX. (Loudest), LOW, or OFF.

**START/HOLD button** - This multi-function button is used to:

- **START** the game when all options have been selected.
- **HOLD** to put dartboard in **HOLD** status between rounds to allow player to remove darts from the target area.

**DART OUT/SCORE button** - The estimate feature is active only during the "01" games (301, 401, etc.). When a player's score falls below 160, he/she can press the **DART OUT** button and get a suggestion from the dartboard as to the 3 darts needed to finish the game. Note doubles and triples are indicated with 2 and 3 dashes to the left of the number respectively. The **SCORE** feature allows player to access score not current on display.

**BOUNCE OUT button** - Decide before play if you want to count darts that do not remain in board ("bounce-outs") or not. If not, simply press the **BOUNCE OUT** button immediately after a bounce out occurs to deduct the score that registers.

**DELETE button** - Press this to delete a score made by error. For example, if you forget to activate the **HOLD** status before removing darts and a score registers simply press **DELETE** to remove score.

**CYBERMATCH button** – Press to select skill level of CyberMatch opponent. See page 6 for detailed instructions.

## **Electronic Dartboard Operation**

1. Press the **POWER** switch to activate dartboard. A short musical introduction is played as the display goes through power-up test.
2. Press **GAME** button until desired game is displayed (see game chart on page 20).
3. Press **DOUBLE button** (optional) to select starting and/or ending on doubles (used only in 301 - 901 games). This is explained in the game rules section.
4. Press **PLAYER** button to select the number of players (1, 2, ... 8). The default setting is 2 players.
5. Press **START/HOLD** button (red) to activate game and begin play.
6. Throw darts
  - The dart indicator display is located above the numbers in the LED displays. The lights indicate the number of darts thrown in the round.
  - When all 3 darts have been thrown, a voice command will indicate “next player” and the score will flash. The darts can now be removed without affecting the electronic scoring. When all darts are removed from the playing surface press the **START** button to go to next player. Voice command will indicate which player is up. Also, the player indicator lights will illuminate to show which player’s turn it is.

## **Temporary Score Display**

This electronic dartboard is equipped with a Temporary Score display. This display - located to the far left of the display panel. This LED will display each dart’s score immediately and remain until the next dart is thrown. This display is also utilized for several games.

## **Display Protective Film**

This electronic dartboard may have a clear film over the entire display area to prevent scratching during shipping. It is recommended that you remove this film so display is easier to read. To remove, simply lift edge and peel off.

## CyberMatch 2000 Feature

This exciting feature allows solo player to play against the computer at one of five different levels of skill! Only 1 player can compete against the CyberMatch competitor at a time. The CyberMatch feature adds a level of competition to normally routine practice sessions.

### To activate the CyberMatch opponent:

1. Select the Game you wish to play
2. Press **CYBERMATCH** button  
Select CyberMatch opponent skill level by pressing the **CYBERMATCH** button continually

### CyberMatch Levels

Level 1 (C1)	Professional
Level 2 (C2)	Expert
Level 3 (C3)	Advanced
Level 4 (C4)	Intermediate
Level 5 (C5)	Beginner

3. Press **START** to begin play

### When play begins:

The 'human' player throws first. After 3 darts are thrown, go to the board to take darts out and press **START** to change to the next player (CyberMatch). Watch as the CyberMatch opponent's dart scores are registered on the display. After the CyberMatch opponent completes his round, the board will **automatically reset** for the "human" player. Play continues until one player wins. **Good luck!**

## Caring for your Electronic Dartboard

1. **Never use metal tipped darts on this dartboard.** Metal tipped darts will seriously damage the circuitry and electronic operation of this dartboard.
2. **Do not use excessive force when throwing darts.** Throwing darts too hard will cause frequent tip breakage and cause excess wear on the board.
3. **Turn darts clockwise as you pull them from the board.** This makes it easier to remove darts and extends the life of the tips.
4. **Use only the A/C adapter that comes with the dartboard.** Using the wrong adapter may cause electrical shock and damage to the electronic circuits.
6. **Do not spill liquids on the dartboard.** Do not use spray cleaners, cleaners that contain ammonia or other harsh chemicals, as they may cause damage.

## **Cricket Scoring Display**

This dartboard utilizes a dedicated scoreboard that keeps track of each player's segment status when playing Cricket. When Cricket is selected, all lights on the Cricket scoreboard will light up - there are 3 separate lights within each number (15 through 20 and bullseye). During play, one of the status lights will turn off as a segment is hit. If a double or triple of an active number is hit, 2 or 3 lights will turn off respectively.

## **Built-In Dart Holders**

This electronic dartboard & cabinet set is equipped with built-in dart holders on the left and right hand sides of the board surface and on the inner doors of the cabinet. There are enough holders to hold six darts on the board. Note, cabinet will not close if darts are stored in dartboard holders. When closing cabinet, store your darts on the inner cabinet doors.

## **Sound Effects Demo**

To hear your dartboard play through all the voice commands and sound effects follow this procedure: 1) With power off press **CYBERMATCH** button; 2) Turn Power switch ON; 3) Press the **BOUNCE OUT** button and you will hear sound effects demo.



## Game Rules

The **Manchester** electronic dartboard is loaded with games and options. The rules for each game are detailed below in the order they appear on the LED display when paging through the games. An illustration of the LED displays is indicated next to the game description for your reference. Please note the characters may appear slightly different than illustrated here.

**301**      G 0 1   s t d   3 0 1   2 p

This popular tournament and pub game is played by subtracting each dart from the starting total until the player reaches exactly 0 (zero). If a player goes past zero it is considered a “*Bust*” and the score returns to where it was at the start of that round. For example, if a player needs a 32 to finish the game and he/she hits a 20, 8, and 10 (totals 38), the score goes back to 32 for the next round.

In playing the game, the double in / double out option can be chosen (double out is the most widely used option). Simply press the “DOUBLE” button to change this setting. LED indicators will display your current setting:

- **Double In** - A double must be hit before points are subtracted from the total. In other words, a player’s scoring does not begin until a double is hit.
- **Double Out** - A double must be hit to end the game. This means that an even number is necessary to finish the game.
- **Double In and Double Out** - A double is required to start and end scoring of the game by each player.

### ***Estimate Feature (“01” games only)***

The **Pro 5400** electronic dartboard has a special “**ESTIMATE**” feature. When a player requires less than 160 to reach zero, the estimate feature becomes active. The player can press the **ESTIMATE** button to view the darts necessary to throw to finish the game (reach zero exactly). Doubles and triples are indicated with 2 or 3 lines to the left of each number respectively.

**Adjustable Difficulty Settings for 301** include 401, 501, 601, 701, 801, and 901. To change to these more difficult settings, simply press the SELECT button. Each option is played exactly as outlined for 301 with the exception of the starting total; 401 has starting total of 401 points; 501 has starting total of 501 points and so on up to 901.

**CRICKET**    **G02**   **cri**   **std**   **2 p**

Cricket is a strategic game for accomplished players and beginners alike. Players throw for numbers best suited for them and can force opponents to throw for numbers not as suitable for them. The object of Cricket is to “close” all of the appropriate numbers before one’s opponent while racking up the highest number of points.

**Only the numbers 15 through 20 and the inner/outer bullseye are used.** Each player must hit a number 3 times to “open” that segment for scoring. A player is then awarded the number of points of the “open” segment each time he/she throws a dart that lands in that segment, provided their opponent has not closed that segment. Hitting the double ring counts as two hits, and the triple ring counts as 3 hits.

Numbers can be opened or closed in any order. A number is “closed” when the other player(s) hit the open segment 3 times. Once a number has been “closed”, any player for the remainder of the game can no longer score on it.

*Winning* - The side closing all the numbers first and accumulating the highest point total is the winner. If a player “closes” all numbers first but is behind in points, he/she must continue to score on the “open” numbers. If the player does not make up the point deficit before the opposing player(s) “closes” all the numbers, the opposing side wins. Play continues until all segments are closed - the winner is the player with the highest score.

The Cricket segment scoring is easy to understand. Each segment has 3 lights to indicate the number of hits necessary to open/close it. As a segment is hit (“mark”) a light will turn off, thus updating the number of hits remaining to open/close. The LED display is utilized for this scoring as illustrated below. Please feel free to call our Customer Service department if you need further explanation.

**NO-SCORE CRICKET**    **G02**   **cri**   **nc**   **2 p**

(Press SELECT button when **Cricket** is displayed)

Same rules as standard Cricket except there is no point scoring. The object of this version is to be the first to simply “close” all the appropriate numbers (15 through 20 and the bullseye).

**CUT-THROAT CRICKET****G 0 3****c u t****c r i****2 p**

Same basic rules as standard Cricket except once scoring begins, points are added to your opponent(s) total. The object of this game is to end up with the fewest points. This variation of Cricket offers a different psychology to the players. Rather than adding to your own score and helping your own cause as in standard Cricket, Cut-Throat offers the benefit of racking up points for your opponent(s), digging him in a deeper hole. Competitive players will love this variation!

**SCRAM****G 0 4****s c r****1-1*****(For 2 players only)***

This game is a variation of Cricket. The game consists of two rounds. The players have a different objective in each round. In round 1, player 1 tries to “close” (score 3 hits in each segment - 15 to 20 and bullseye). During this time, player 2 attempts to rack up as many points in the segments that the other player has not yet closed. Once player 1 has closed all segments, round 1 is complete. In round 2, each player’s roles are reversed. Now, player 2 tries to close all the segments while player 1 goes for points.

The game is over when round 2 is complete (player 2 closes all segments). The player with the highest point total is the winner.

**ENGLISH CRICKET****G 0 5****e n g****1-1*****(For 2 players only)***

This game is another variation of Cricket that requires precision dart throwing. The game consists of two rounds. The players have a different objective in each round. During the first round, player 2 attempts to throw bullseyes – with the objective of needing 9 to complete round 1. Double bull (red center) counts as 2 scores. Any throw that does not hit bullseye is credited to player 1’s point total. For example, if player 2 throws a 20, a single bullseye, and a 7 during his/her turn, player 2 will have one bullseye subtracted from the 9 needed, and 27 points will be credited to player 1’s point total. Player 2 must exhibit accurate bullseye dart throwing!

Meanwhile, player 1 attempts to score as many points as possible during this first round. Doubles and triples count 2x and 3x their respective values. However, to score points, player 1 must score over 40 points in each turn (3 throws) to amass points against player 2. Only those points over 40 are counted toward the cumulative score. Player 1 must also exhibit precision dart throwing and avoid hitting any bullseyes during this first round because any hits scored by player 1 in the bullseye area will be subtracted from player 2’s needed total of 9 bullseyes.

Once player 2 reaches the objective of getting 9 bullseyes, the roles are reversed for round two.

**COUNT-UP**

G 0 6   c u p   3 0 0   2 p

The object of this game is to be the first player to reach the specified point total. Point total is specified when the game is selected. Each player attempts to score as many points as possible per round. Doubles and triples count 2 or 3 times the numerical value of each segment. For example a dart that lands in the triple 20 segment is scored as 60 points. The cumulative scores for each player will be displayed in the LED display as the game progresses.

**Adjustable Difficulty Settings** for Count-Up include 400, 500, 600, 700, 800, 900, and 999. To change to these more difficult settings, simply press the SELECT button. Each option is played exactly as outlined above with the exception of the total necessary to win the game. For example, in Count-Up 500, the first player to reach 500 points is the winner.

**HIGH SCORE**

G 0 7   h s c   3 r   2 p

The rules for this competitive game are simple - Rack up the most points in three rounds (nine darts) to win. Doubles and triples count as 2x and 3x that segment's score respectively.

**Adjustable Difficulty Settings** for High Score include 4 rounds, 5 rounds, ... 14 rounds. Each option is played exactly as outlined above with the exception of the number of rounds in the game. For example, in High Score 7 rounds, the player with the most points after 7 rounds is the winner.

**ROUND-THE-CLOCK**

G 0 8   r o n   R 1   2 p

Each player attempts to score in each number from 1 through 20 and bullseye **in order**. Each player throws 3 darts per turn. If a correct number is hit, he/she tries for the next number in sequence. The first player to reach 20 is the winner. The display will indicate which segment you are shooting for. A player must continue shooting for a segment until it is hit. The display will then indicate the next segment you should shoot for.

There are many difficulty settings available for this game. Each game has the same rules, the differences are detailed as follows:

**ROUND-THE-CLOCK 5** - Game starts at segment number 5

**ROUND-THE-CLOCK 10** - Game starts at segment number 10

**ROUND-THE-CLOCK 15** - Game starts at segment number 15

Since this game does not utilize point scoring, the double and triple rings count as single numbers.

***We have added some new levels of difficulty to this game for those looking for a real challenge:***

**ROUND-THE-CLOCK Double** - Player must score a **Double** in each segment from 1 through 20 in order.

**ROUND-THE-CLOCK Double 5** - Game starts at double segment 5

**ROUND-THE-CLOCK Double 10** - Game starts at double segment 10

**ROUND-THE-CLOCK Double 15** - Game starts at double segment 15

**ROUND-THE-CLOCK Triple** - Player must score a **Triple** in each segment from 1 through 20 in order.

**ROUND-THE-CLOCK Triple 5** - Game starts at triple segment 5

**ROUND-THE-CLOCK Triple 10** - Game starts at triple segment 10

**ROUND-THE-CLOCK Triple 15** - Game starts at triple segment 15

## **KILLER**

G09	h11	= 3	2 p
-----	-----	-----	-----

This game will really show who your friends are. The game can be played with as few as two players, but the excitement and challenge builds with even more players. To start, each player must select his number by throwing a dart at the target area. The LED display will indicate "SEL" at this point. The number each player gets is his assigned number throughout the game. No two players can have the same number. Once each player has a number, the action starts.

Your first objective is to establish yourself as a "Killer" by hitting the double segment of your number. Once your double is hit, you are a "Killer" for the rest of the game. Now, your objective is to "kill" your opponents by hitting their segment number until all their "lives" are lost. The last player to remain with lives is declared the winner. It is not uncommon for players to "team up" and go after the better player to knock him out of the game.

**Adjustable Difficulty Settings** for Killer include 7 lives, 8 lives, ... 14 lives. Each option is played exactly as outlined above with the exception of the number of lives each player has in the game. In addition, for those who really want a challenge, there are three additional difficulty settings: Doubles 3 lives, Doubles 5 lives, and Doubles 7 lives. In these games, you can only "Kill" opponents by scoring doubles in their number segment.

## **DOUBLE DOWN**

G10	d o n		2 p
-----	-------	--	-----

Each player starts the game with 40 points. The object is to score as many hits in the active segment of the current round. The first round, the player must throw for the 15 segment. If no 15's are hit, his score is cut in half. If some 15's are hit, each 15 (doubles and triples count) is added to the starting total. The next round players throw for the 16 segment and hits are added to the new cumulative point total. Again, if no hits are registered, the point total is cut in half.

Each player throws for the numbers as indicated in the chart below in order (the LED screen will indicate the active segment in which to throw). The player who completes the game with the most points is the winner.

	15	16	D	17	18	T	19	20	B	TOTAL
Player 1										
Player 2			▲			▲				

Any Double

Any Triple

**DOUBLE DOWN 41**

G11 f 41 [ ] 2 p

This game follows similar rules as standard Double Down as described above with two exceptions. First, instead of going from 15 through 20 and bullseye, the sequence is reversed which will be indicated on the LED display. Second, an additional round is included toward the end in which players must attempt to score three hits that add up to 41 points (20, 20, 1; 19, 19, 3; D10, D10, 1: etc.). This “41” round adds an extra level of difficulty to the game. Remember, a player’s score is cut in half if not successful, so the “41” round presents quite a challenge!

	20	19	D	18	17	T	16	15	41	B	TOTAL
Player 1											
Player 2			▲			▲			▲		

Any Double

Any Triple

‘41’ Round

**ALL FIVES**

G12 a l l 51 2 p

The entire board is in-play for this game (all segments are active). With each round (of 3 darts) each player has to score a total which is divisible by 5. Every “five” counts as one point. For example 10, 10, 5 = 25. Since 25 is divisible by 5 fives, this player scores 5 points (5 x 5 = 25).

If a player throws 3 darts that are not divisible by 5, no points are given. Also, the last dart of each round must land in a segment. If a player throws the third dart and it lands in the catch ring area (or misses the board completely), he earns no points even if the first two darts are divisible by 5. This prevents a player from “tanking” the third throw if his first two are good. The first player to total fifty-one (51) “fives” is the winner. The LED screen will keep track of the point totals.

**Adjustable Difficulty Settings** for All Fives include 51, 61, 71, 81, and 91. Each option is played exactly as outlined above with the exception of the number of points (or fives) it takes to win the game.

**SHANGHAI**

G13 | s h i | 1 | 2 p

Each player must progress around the board from 1 through 20 in order. Players start at number 1 and throw 3 darts. The object is to score the most points possible in each round of 3 darts. Doubles and triples count toward your score. The player with the highest score after completing all twenty segments is the winner.

**Adjustable Difficulty Settings** for Shanghai include the following options:

**SHANGHAI 5** - Game starts at segment 5

**SHANGHAI 10** - Game starts at segment 10

**SHANGHAI 15** - Game starts at segment 15

In addition, we added **Super Shanghai** as a difficulty option. This game is played exactly as described above except various doubles and triples must be hit as specified by the LED display.

**Adjustable Difficulty Settings** for Super Shanghai include the following options:

**SUPER SHANGHAI 5** - Game starts at segment 5

**SUPER SHANGHAI 10** - Game starts at segment 10

**SUPER SHANGHAI 15** - Game starts at segment 15

**GOLF**

g14 | g o l | 9 h | 2 p

This is a dartboard simulation of the game golf (but you don't need clubs to play). The object is to complete a round of 9 through 18 "holes" with the lowest score possible. The Championship "course" consists of all par 3 holes making par 27 for a nine hole round or 54 for a round of 18.

The segments 1 through 18 are used with each number representing a "hole." You must score 3 hits in each hole to move to the next hole. Obviously, double and triples affect your score as they allow you to finish a hole with fewer strokes. For example, throwing a triple on the first shot of a hole it is counted as an "eagle" and that player gets a completes that hole with 1 "stroke."

Note: **The active player continues to throw darts until he "holes out"** (scores 3 hits on the current hole). The voice announcer will indicate the player that is up - listen carefully to avoid shooting out of sequence. By the way, there are no "gimmes" in this game!

**FOOTBALL**

G15 | f o t | | 2 p

Strap your helmet on for this game! The first thing necessary is to select each player's "playing field." This can be done by throwing a dart or by manually pressing a segment on the board by each player. This is entirely up to you, but whichever segment is selected becomes your starting point which carries through the bullseye and directly across to the other side of the bullseye.

For example, if you select the 20 segment, you start on the double 20 (outer ring) and continue all the way through to the double 3. The “field” is made up of 11 individual

segments and must be hit in order. So, keeping with the example above, you must throw darts in the following segments in this order:

Double 20 ... Outer Single 20 ... Triple 20 ... Inner Single 20 ... Outer Bullseye ... Inner Bullseye ... Outer Bullseye ... Inner Single 3 ... Triple 3 ... Outer Single 3 ... and finally a Double 3.

The First player to “score” is the winner. The LED display will keep track of your progress and indicate the segment you need to throw for next.

**BASEBALL**



This dartboard version of baseball takes a great deal of skill. As in the real game, a complete game consists of 9 innings. Each player throws 3 darts per “inning.” The field is laid out as shown in the diagram.

<b>Segment</b>	<b>Result</b>
Singles segments	“Single” - one base
Doubles segment	“Double” - two bases
Triples segment	“Triple” - Three bases
Bullseye	“Home Run” ( <i>can only be attempted on third dart of each round</i> )

The object of the game is to score as many runs as possible each inning. The player with the most runs at the end of the game is the winner.

**STEEPLECHASE**



The object of this game is to be the first player to finish the “race” by being the first to complete the “track.” The track starts at the 20 segment and runs clockwise around the board to the 5 segment and ends with a bullseye. Sounds easy right? What has not yet been specified is that you must hit the inner single segment of each number to get through the course. This is the area between the bullseye and the triples ring. And, as with a real steeplechase, there are obstacles throughout the course to hurdle. The four hurdles are found at the following places:

- 1<sup>st</sup> fence                  Triple 13                  • 2<sup>nd</sup> fence                  Triple 17
- 3<sup>rd</sup> fence                  Triple 8                  • 4<sup>th</sup> fence                  Triple 5

The first player to complete the course and hit the bullseye wins the race.

**BOWLING**

G18 | b o l | 10 | 2 p

This dartboard adaptation of bowling is a real challenge! It is a difficult game in that you must be very accurate to rack up a decent score. Player one starts the game. You must select your “alley” by either throwing dart or manually pressing segment of choice. Once alley is selected, you have 2 remaining darts to throw in which to score points or “pins.” Each specific segment in your “alley” is worth a given pin total:

Diagram

<b><u>Segment</u></b>	<b><u>Score</u></b>
Double	9 pins
Outer Single	3 pins
Triple	10 pins
Inner Single	7 pins

There are several rules for this game as follows:

1. A perfect game score would be 200 in this version of bowling
2. You cannot hit the same singles segment twice within the same “frame” (round). The second hit will count as zero points. **Hint:** Try to hit each single to reach 10 points in the frame.
3. You can score 20 points per “frame” by hitting the triple segment twice.
4. Hitting the double segment with your second dart will only count as 10 points if you scored a double on your first throw. Otherwise you will score a total of 9 points by throwing a double with your second dart.

**CAR RACING**

G19 | c a r | | 2 p

This game is similar to steeplechase except we let you set up your own “race track.” You can set up as many obstacles as you wish. The track must be 20 lengths long.

Before the game starts, the LED display will prompt you to select the course (“SEL”). Players should alternate selecting segments by pressing on the specific segment of your choice. Note: You will have to hit the exact segment you selected to move on during the race. If you choose inner single 20, that inner single area will need to be hit during the race. The LED display will indicate inner single with a line next to the bottom of the 1, an outer single is shown with a line next to the top portion of the 1.

Obstacles usually comprise hitting a difficult number before continuing on the racetrack. Again, the route can be made as difficult or easy as you wish and can go anywhere on the target area of the board.

After the track is selected, press START to begin the race. The first player to complete the course is the winner.

**SHOVE A PENNY**G 2 0   p e n      2 p

Only the numbers 15 through 20 and the bullseye are used. Singles are worth 1 point, doubles are worth 2, and triples are worth 3 points. Each player must throw for the numbers in order with the objective of scoring 3 points in each segment to move on to the next. If a player scores more than 3 points in any one number, the excess points are given to the next player. The first player to score 3 points in all segments (15 - 20 and bull) is the winner.

**NINE-DART CENTURY**G 2 1   n l n      2 p

The object of this game is to attempt to score 100 points, or come as close as possible, after 3 rounds (9 darts). Doubles and triples count as 2x and 3x their value respectively. Going over 100 points is considered a "bust" and causes you to lose unless all players go over. In that case, the player closest to 100 wins (player that scored the lowest amount over 100).

**GREEN VS. RED**G 2 2   g - r      1-1

*(2 players only)*

This game is a race around the board, where skill at hitting doubles and triples pays off with victory. Player 1 is "green" and player 2 is "red." Player 1 shoots for only doubles and triples that are green and works around the board clockwise. Player 2 starts at 20 and works around the board counter-clockwise, shooting for red segments (the temporary score display will indicate which segment to throw for). Note: a maximum of one double and one triple of the same number can be scored in a single round.

What's more, hitting the wrong number (of your opponent's color) **subtracts** that amount from your score - so be careful.

The player with the most points after completion of the game is the winner.

**GOLD HUNTING**

G 2 3   g h n   1 0   2 p

The object of this game is to find "gold." You collect gold for each 50 points. Gold is only collected only if your score is exactly 50 or a multiple of 50 (100, 150, etc.) at any point during a round. However, since "gold" can make a person greedy, not only do you collect gold for every multiple of 50, you also steal 1 gold from all other players. Therefore, as you collect a gold, you take 1 gold from all other players who have gold.

This is a real back-and-forth game, but the player who reaches to selected total gold required first is the winner.

**CASINO - FLUSH**

G 2 4   c a s   2 6 0   2 p

This game, inspired by casino play, tests your nerve and skill as you gamble points to defeat your opponent. The object of the game is to be the first player to reach the designated point total.

The end-game point total can be changed by pressing the **SELECT** button. Available options include; 260, 310, 360, 410, 460, 510, and 560. Press START button and you're ready to go.

The dartboard will indicate the number you must throw for. The default "bet" is 10 points. However, each player can increase his bet at the start of each round to 20, 30, 40, ... 90 points. Players usually wager high when a number appears they are confident in hitting. To change your bet (at start of a round) press the **BOUNCE OUT** button. Your new bet will be indicated in the display (for example, "b20" will appear to indicate a bet of 20 points). The bet will automatically revert to 10 points at the start of each round.

To "cash in" on your bet, you need to hit the indicated number segment. Hitting a single on the first throw is a "push" and does not score points. However throwing a double or triple of the correct segment on the first throw counts as 1x and 2x your bet respectively. Your next two darts in the round count as 1x, 2x, and 3x your bet for a single, double, or triple. The segment scoring display will light to indicate the number of successful hits you have registered. Failing to hit the active segment in a round costs you the value of the bet you selected at the start of the round.

The first player to reach the designated point total is the winner.

**CASINO B - STRAIGHT**

G 2 5   c s b   2 6 0   2 p

This game, while similar to Casino A, has an added element of play. Again, the object of the game is to be the first player to reach the designated point total.

The end-game point total can be changed by pressing the **SELECT** button. Available options include; 260, 310, 360, 410, 460, 510, and 560. Press START button and you're ready to go.

The dartboard will indicate the number you must throw for. The default "bet" is 10 points. However, each player can increase his bet at the start of each round to 20, 30, 40, ... 90 points. Players usually wager high when a number appears they are confident in hitting. To change your bet (at start of a round) press the **BOUNCE OUT** button. Your new bet will be indicated in the display (for example, "b20" will appear to indicate a bet of 20 points). The bet will automatically revert to 10 points at the start of each round.

To "cash in" on your bet, you need to hit the indicated number segment. Hitting a single on the first throw is a "push" and does not score points. However throwing a double or triple of the correct segment on the first throw counts as 1x and 2x your bet respectively. **This is where the new element comes into play.** Instead of throwing for the same segment

during each round, your sequence is to span across the target area. For example, if the display indicated to throw for segment 1, you attempt to throw for segment 1, followed by a

bullseye, followed by segment 19. The temporary score display will indicate segment to aim for after each throw.

Your next two darts in the round count as 1x, 2x, and 3x your bet for a single, double, or triple (bullseye segment has no triple area). The segment scoring display will light to indicate the number of successful hits you have registered. Failing to hit the active segment in a round costs you the value of the bet you selected at the start of the round.

The first player to reach the designated point total is the winner.

### **CASINO C - 3-STAR**

G 2 6
-------

c s c
-------

2 6 0
-------

2 p
-----

This version of Casino is very difficult, as you need to score at least 3 hits in the active segment during each round to score points. Again, the object of the game is to be the first player to reach the designated point total.

The end-game point total can be changed, as with the other versions, by pressing the **SELECT** button. Available options include; 260, 310, 360, 410, 460, 510, and 560. Press **START** button and you're ready to go.

Only the segments 15 through 20 and bullseye are active in this game. The segment scoring display will be lit at the start of each round. The default "bet" is 10 points. However, each player can increase his bet at the start of each round to 20, 30, 40, ... 90 points. Players usually wager high when a number appears they are confident in hitting.

To change your bet (at start of a round) press the **BOUNCE OUT** button. Your new bet will be indicated in the display (for example, "b20" will appear to indicate a bet of 20 points). The bet will automatically revert to 10 points at the start of each round.

To "cash in" on your bet, you need to hit an active segment (15 - 20 and bullseye) 3 times or score a triple "opens" the segment for scoring and that player receives 3 times the value of his bet. Doubles and triples count as 2 and 3 hits respectively. Failing to hit a segment 3 times forces that player to lose the value of his bet. Also, hits within segments are **not** carried over to the next round. The first player to reach the designated point total is the winner.

**Game Chart**

## **Important Notes**

### ***Stuck Segment***

Occasionally, a dart will cause a segment to become wedged within the segment separator web. If this happens, all play will be suspended and the LED display will indicate the segment number that is stuck.

To free the segment, simply remove the dart or broken tip from the segment. If the problem is still not solved, try wiggling the segment until it is loose. The game will then resume where it left off.

### ***Broken Tips***

From time to time a tip will break off and become stuck in the segment. Try to remove it with a pair of pliers or tweezers by grasping the exposed end and pulling it out of the segment. If this is not possible, you can attempt to push the tip through to the back of the segment. Use a nail that is smaller than the hole and gently push the tip until it falls through the other side. Be careful not to push too far and damage the circuitry behind the segment.

Don't be alarmed if tips break. This is a normal occurrence when playing soft tip darts. We include a pack of 40 replacement tips, which should keep you supplied for quite some time. When replacing tips, make sure you use the same type of tips that come with this dartboard.

### ***Darts***

It is recommended that you do not use darts that exceed 17 grams on this dartboard. The darts included with this dartboard are 10 grams and use standard soft tips. Replacement tips are available at most retailers carrying dart products.

## **Cleaning your Electronic Dartboard**

Your Halex electronic dartboard will provide many hours of competition if cared for properly. Regular dusting of the cabinet is recommended using a damp cloth. A mild detergent can be used if necessary. The use of abrasive cleaners or cleaners that contain ammonia may cause damage and should not be used. Avoid spilling liquid onto the target area since it can result in permanent damage and is not covered by the warranty.

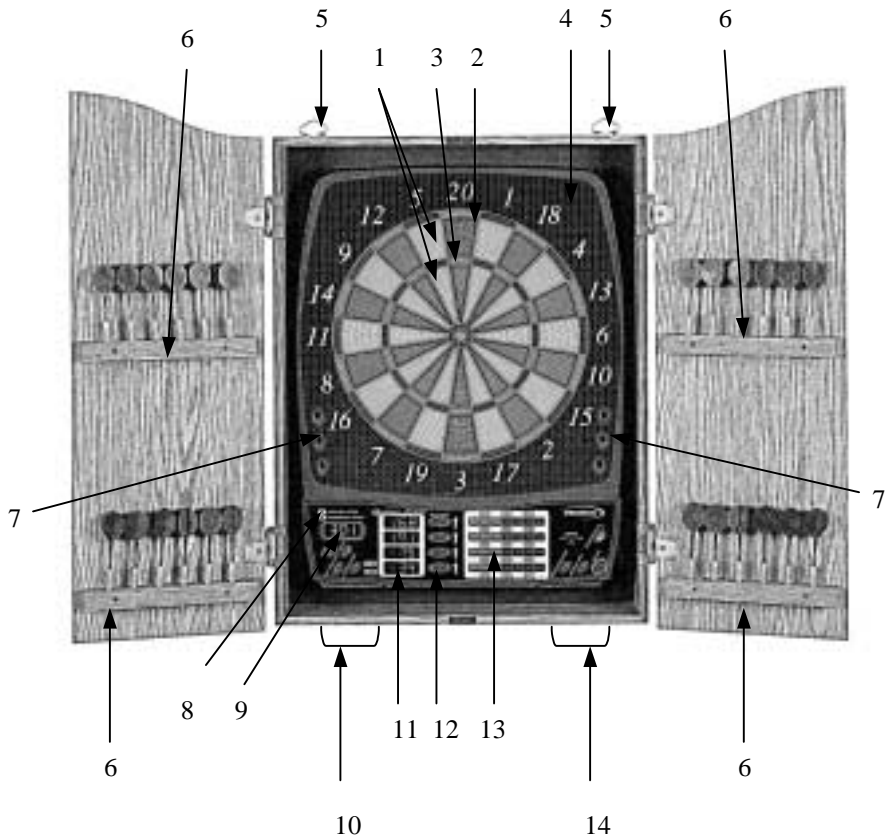

- |                                      |   |
|--------------------------------------|---|
| 1. Singles Ring                      | 10 Double/Miss Button   |
| 2. Triples Ring                      | Player/Page button, Select Button, Game Button  |
| 3. Doubles Ring                      | 11. LED Score Displays  |
| 4. Catch Ring Button                 | 12. Player Indicator  |
| 5. Cabinet Hanger                    | 13. Cricket Scoring Displays  |
| 6. Dart Holders                      | 14. Start/Hold Button, Cybermatch/Delete Button, Bounce Out Button, Dart Out/Score Button |
| 7. Built-in Dart Holders             |   |
| 8. Double In / Double Out Indicators |   |
| 9. Active Score Display              |   |

## **Accessories / Spare Parts**

<b><u>Item #</u></b>	<b><u>Description</u></b>	<b><u>Price</u></b>
100-64678	Electronic Dartboard Storage Compartment	\$ 9.95
100-64675	12 darts with replacement Tips	\$ 6.95
100-64670	AC Adapter	\$11.95
68950	Aluminum Shafts (3 pack)	\$ 2.95
68750	48-pack replacement tips	\$ 5.95
68670	Metallic Flights (3 pack). Assorted Styles	\$ 3.25
67200	English-Style brass Soft Tip darts (3 pack) 16 grams	\$ 7.95
68730	Soft Tip Accessory Pack (4 sets of flights, 1 set of aluminum shafts, 48 soft tips)	\$ 8.95

*Prices include shipping and handling.*

### **To place order:**

#### ***MasterCard/Visa***

Call Customer Service at 877-516-9707 (Toll-Free) and specify item number. Have your credit card number ready when you place call.

#### ***Mail***

Make check payable to: **Regent Sports Corporation** and send to the following address:

45 Ranick Road  
Hauppauge, NY 11788  
Attn: Customer Service

*Please do not send cash. Please indicate item # on check.*

**Also, be sure to check out our web site at:**

**[www.regent-halex.com](http://www.regent-halex.com)**

• **Parts Ordering** • **Owners Manuals** • **Product Information**



© 1999  
Regent Sports Corporation  
Hauppauge, New York 11788